

1. Contents

1.	Contents	2
2.	Key to symbols	2
3.	General safety instructions	2
4.	Overview of product	3
5.	Initial operation	5
6.	Technical data	11
7.	EU Declaration of Conformity	11

2. Key to symbols



Danger of personal injury!
The safety instructions must be observed!



Warning! Danger to property!
The safety instructions must be observed!



Information
Reference to other sources of information.

3. General safety instructions

Guarantee

The function and safety of the equipment is only guaranteed if the warning and safety instructions included in these operating instructions are adhered to.

Chamberlain GmbH is not liable for any personal injury or damage to property that occurs as a result of the warning and safety instructions being disregarded.

Using the equipment for its intended purpose

The AS 210 B controls are intended exclusively for controlling door systems.

The controls may only be used in dry rooms.

Target group

Only qualified and trained electricians may connect, programme and service the controls.

Qualified and trained electricians meet the following requirements:

- have knowledge of the general and specific safety and accident prevention regulations,
- have knowledge of the relevant electrical regulations,
- are trained in the use and care of appropriate safety equipment,
- are capable of recognising the dangers associated with electricity.

Instructions for installation and connection

- The controls must be disconnected from the electricity supply before carrying out electrical works. It must be ensured that the electricity supply remains disconnected during the works.
- Local protective regulations must be complied with.
- Mains cables and control cables must be laid separately.

4. Overview of product

GB

Regulations and bases for testing

For connecting, programming and servicing, the following regulations must be observed (the list is not exhaustive).

Construction product standards

- EN 13241-1 (Products without fire resistance or smoke control characteristics)
- EN 12445 (Safety in use of power operated doors - Test methods)
- EN 12453 (Safety in use of power operated doors - Requirements)
- EN 12978 (Safety devices for power operated doors and gates - Requirements and test methods)

Electromagnetic compatibility

- EN 55014-1 (Radio disturbance, household appliances)
- EN 61000-3-2 (Disturbances in supply systems - harmonic currents)
- EN 61000-3-3 (Disturbances in supply systems - voltage fluctuations)
- EN 61000-6-2 (Electromagnetic compatibility (EMC) - Part 6-2: Generic standards - Immunity for industrial environments)
- EN 61000-6-3 (Electromagnetic compatibility (EMC) - Part 6-3: Generic standards - Emission standard for residential, commercial and light-industrial environments)

Machinery guidelines

- EN 60204-1 (Safety of machinery, electrical equipment of machines, part 1: general requirements)
- EN 12100-1 (Safety of machinery. Basic concepts, general principles for design. Basic terminology, methodology)

Low voltage

- EN 60335-1 (Household and similar electrical appliances - Safety)
- EN 60335-2-103 (Particular requirements for drives for gates, doors and windows)

Professional association (D)

- BGR 232 (Directive for Power-driven Windows, Doors and Gates)

4.1 Functions

The basic model of the AS 210 B controls is designed only for deadman operation.

The AS 210 B controls can be upgraded with the ZM SKS B plug-in circuit card. With the help of this plug-in card, a closing edge safety device strip can be connected.

The following functions can then be set:

- red traffic light
- yard light
- automatic closing
- excess travel monitoring

4. Overview of product

4.2 Motherboard, AS 210 B

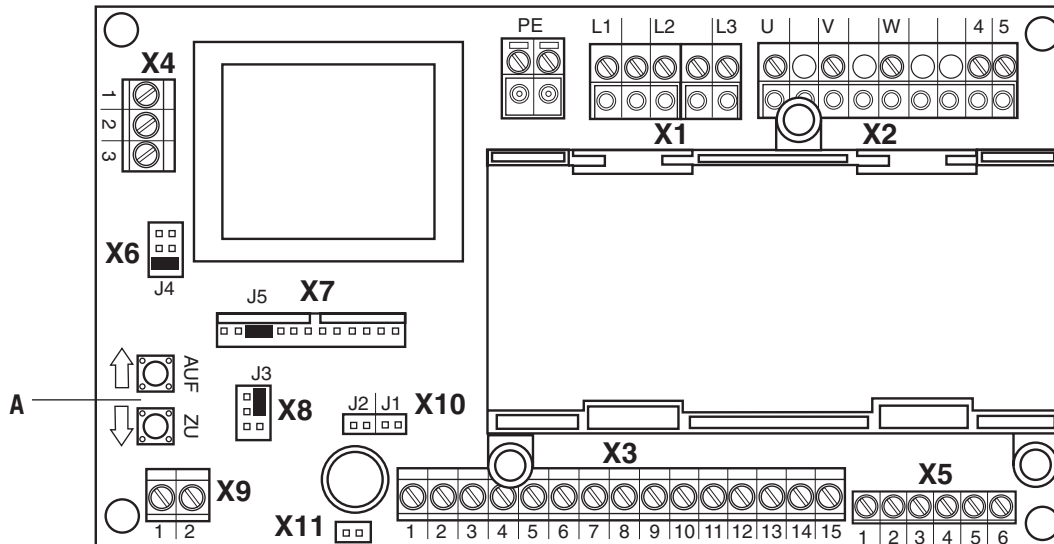

Description:

- A: Setting button OPEN (S01) /
Setting button CLOSE (S02)
- X1: Terminal block for mains connection
- X2: Terminal block for motor / safety circuit for drive
- X3: Terminal block for command devices
- X4: Terminal block for mains voltage selection
- X5: Terminal block for limit switches
- X6: Terminal block for 3-way switch
- X7: Plug-in base for ZM SKS B circuit card
- X8: Plug-in base for spiral cable
- X9: Terminal block for traffic light / yard light
(only in connection with a ZM SKS B plug-in circuit card)
- X10: Terminal block for press-and-release CLOSE- OPEN
- X11: Terminal block for braking relay

5. Initial operation

5.1 General



Warning!

To guarantee that the equipment functions properly, it must be ensured that:

- the door is installed and operational.
- the drive motor is installed and ready for operation.
- the command and safety devices are installed and ready for operation.
- the AS 210 B controls are installed.



Information:

The relevant manufacturers' instructions must be adhered to for the installation of the door, the drive motor, and the command and safety devices.

5.2 Mains connection



Danger!

To guarantee that the controls function properly, the following points must be ensured:

- The mains voltage must correspond to the voltage stated on the type plate.
- For a three-phase current, a clockwise rotating field is required.
- For a permanent connection, an all-pole main switch must be used.
- For a three-phase connection, only 3-way automatic circuit breakers (10A) may be used.

Detailed circuit diagram for mains connection and motor 400 V / 3-phase

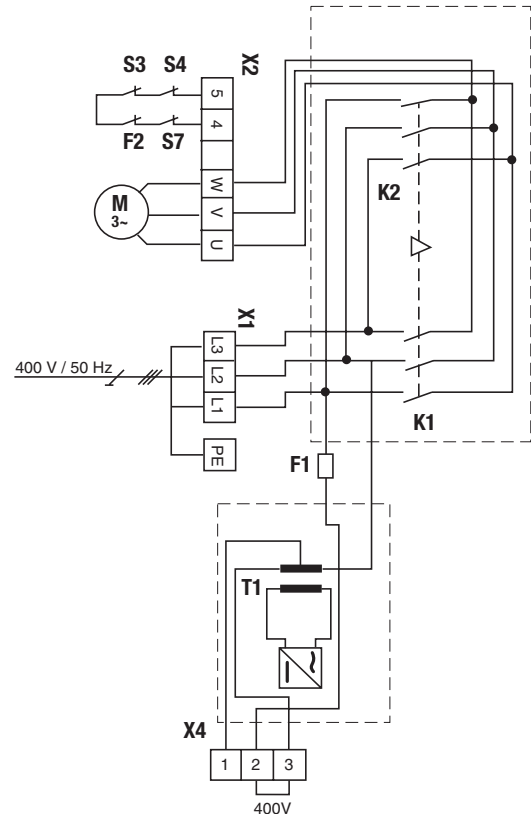

Description:

- F1 Thermal fuse, control voltage
- F2 Thermal overload protection for motor
- K1 Protection OPEN
- K2 Protection CLOSE
- M Motor (400 V / 50 Hz / 3-phase)
- S3 Safety limit switch OPEN (normally closed contact)
- S4 Safety limit switch CLOSE (normally closed contact)
- S7 Safety switch, emergency manual operation (normally closed contact)
- T1 Transformer
- X1 Terminal block for mains connection
- X2 Terminal block for motor
- X4 Terminal block for mains voltage selection

5. Initial operation

Detailed circuit diagram for mains connection and motor 230 V / 3-phase

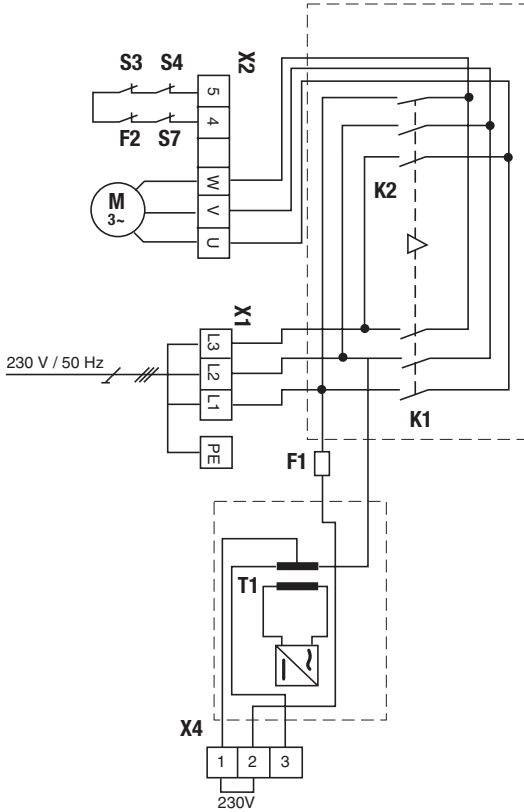

Description:

- F1 Thermal fuse, control voltage
- F2 Thermal overload protection for motor
- K1 Protection OPEN
- K2 Protection CLOSE
- M Motor (230 V / 50 Hz / 3-phase)
- S3 Safety limit switch OPEN (normally closed contact)
- S4 Safety limit switch CLOSE (normally closed contact)
- S7 Safety switch, emergency manual operation (normally closed contact)
- T1 Transformer
- X1 Terminal block for mains connection
- X2 Terminal block for motor
- X4 Terminal block for mains voltage selection

Detailed circuit diagram for mains connection and motor 230 V / single phase

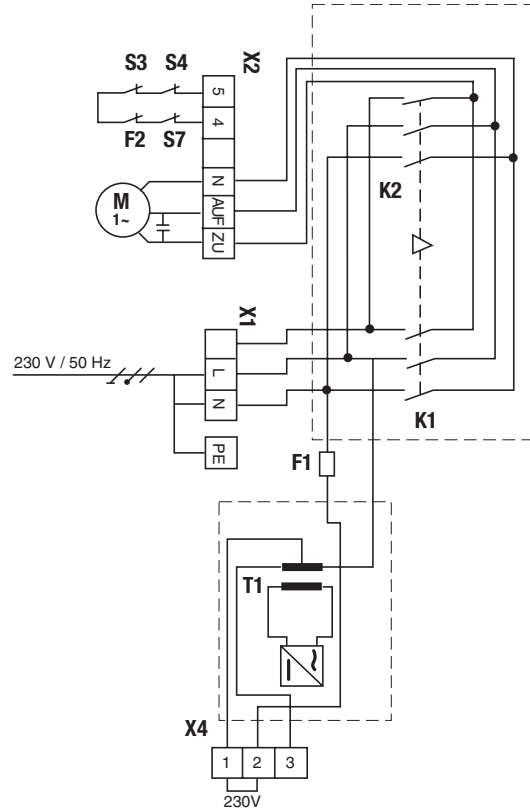

Description:

- F1 Thermal fuse, control voltage
- F2 Thermal overload protection for motor
- K1 Protection OPEN
- K2 Protection CLOSE
- M Motor (230 V / 50 Hz)
- S3 Safety limit switch OPEN (normally closed contact)
- S4 Safety limit switch CLOSE (normally closed contact)
- S7 Safety switch, emergency manual operation (normally closed contact)
- T1 Transformer
- X1 Terminal block for mains connection
- X2 Terminal block for motor
- X4 Terminal block for mains voltage selection

Connection:

- ☛ Connect the controls to the mains power supply.
- ☛ Connect the controls to the motor.
- ☛ Cable groups must be fixed close to their relevant terminals using a cable tie.

5.3 Connection arrangement for limit switches (terminals X5 and X2)

Terminal block X5

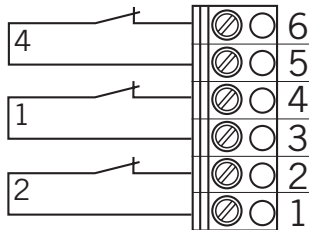

Terminal block X2

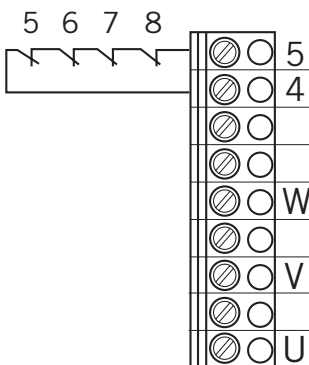

¹ Limit switch OPEN

² Limit switch CLOSE

⁴ Pre-limit switch CLOSE (after activation the door does not reverse)

⁵ Thermal overload protection for motor

⁶ Emergency operation (normally closed contact)

⁷ Safety limit switch CLOSE

⁸ Safety limit switch OPEN

5.4 Connection arrangement for command and safety devices

Command and safety devices can be connected via terminals X3 and X9.

Terminal block X3

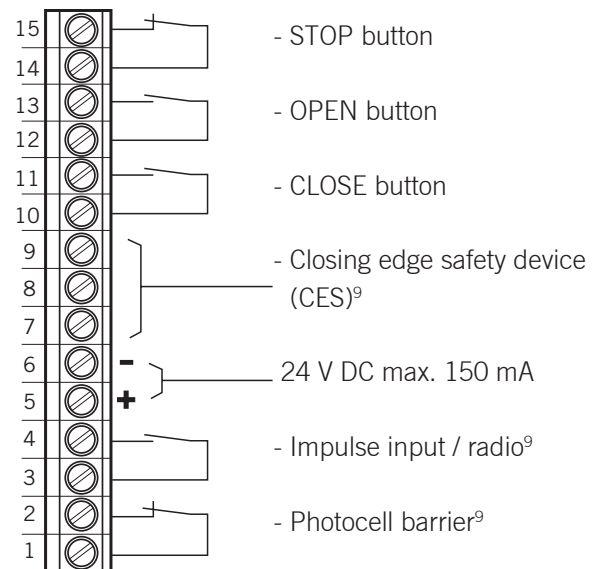

Terminal block X9

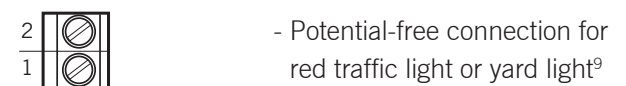

⁹ Only in connection with an ZM SKS B plug-in circuit card

5. Initial operation

5.5 Connection examples for command and safety devices (terminal block X3)

OPEN / STOP / CLOSE buttons

(4-lead solution)

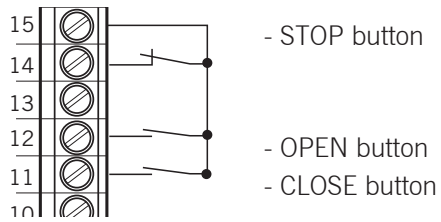

Key switch OPEN / CLOSE

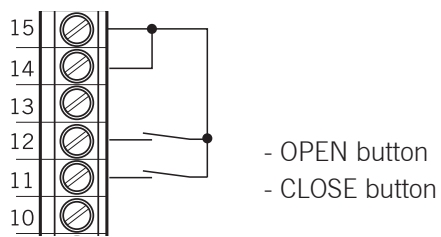

5.6 Connection examples in connection with the ZM-SKS B plug-in module (terminal X3)

For optoelectric closing edge safety device

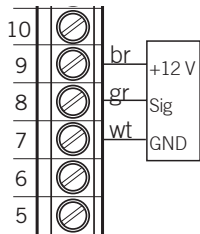

- DIP switch 1 must be set to the OFF position.

For 8.2 kOhm closing edge safety device

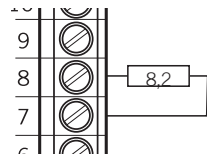

- DIP switch 1 must be set to the ON position.

For pneumatic closing edge safety device

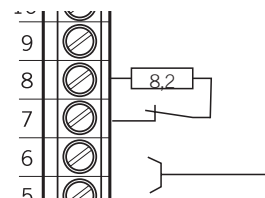

- An 8.2 kOhm resistance must be connected in series with the pressure switch.
- DIP switch 1 must be set to the ON position.
- DIP switch 2 must be set to the ON position.

wt: white
 gr: green
 br: brown

For photocell barrier with 3-lead design

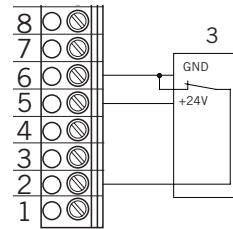

³Photocell barrier (NPN)

5. Initial operation

5.7 Detailed drawings of AS 210 B

X6 - Plug-in base for external 3-way switch

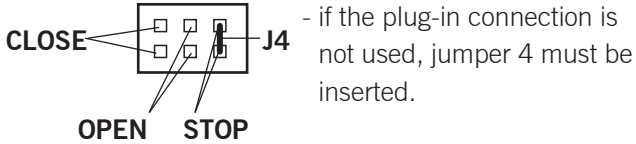

X8 - Plug-in base for spiral cable

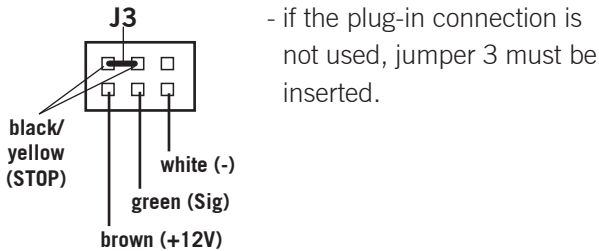

X7 - Plug-in base for ZM SKS B circuit card

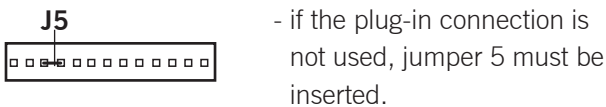

X10 - Plug-in base for press-and-release (OPEN + CLOSE)

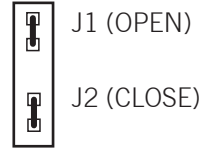

J1 and J2 must be open when used in connection with the ZM SKS B add-on circuit card.



Warning!

If J2 is inserted, the closing edge safety device does not issue a stop command in the closing direction.

X11 - Terminal block for brake relay



Warning!

To avoid damage to the controls, never connect a jumper to X11 under any circumstances.

A brake relay can be connected at terminal block X11 by the manufacturer.

 jumper inserted = press-and-release

 jumper not inserted = deadman

6. Technical data

Dimensions of circuit board:	167 x 85 x 190
Power supply via L1, L2, L3, PE:	230 V or 400 V, 50 / 60 Hz; - max. power input 2200 W - 3.2 A; duty cycle 60% for a maximum running time of 120 s
Fuse protection:	10A K type
Consumption of the controls alone:	max. 100 mA
Control voltage:	24 V DC, max. 250 mA; protected by self-resetting fuse for external sensor systems; all control voltage inputs are galvanically isolated from the supply
Control inputs:	24V DC, all input connections must be potential-free; minimum signal duration for input control command >100 ms
Control outputs:	24 V DC, max. 150 mA
Safety circuit / emergency off:	all input connections must be potential-free; if the safety circuit is interrupted, no further electrically powered movement of the drive is possible, not even in dead-man mode.
Input - safety contact edge:*	for 8.2 kW electrical safety contact edges, terminating resistor and for dynamic optical systems
Relay outputs:*	if inductive loads are connected (e.g. additional relays or brakes), they must be fitted with appropriate interference suppression devices (free-wheeling diodes, varistors, resistor-capacitor elements). Potential-free normally open contact; min. 10 mA ; max. 230V AC / 4A. <i>Contacts used once for power switching can not be subsequently used for connecting small currents.</i>
Temperature range:	In operation: -10°C ... +45°C In storage: -25°C ... +70°C
Air humidity:	up to 80% not condensing
Weight:	approx. 1.8 kg
Guidelines:	Standards

